

Mounting Bracket AT 172

TIME OF USAGE

There is no time limitation for use of the product, provided that annual inspections are performed.

INSTALLATION

In order to install the AT172 mounting bracket, a hexagon socket spanner size 6mm and open-end spanner size 17mm are necessary. To attach the bracket to tripod's leg the following operations should be done (see fig. below):

1. Put the AT172 bracket onto tripod's leg. Pay attention to insert the bracket's pin-'1' into hole-'2' placed on upper surface of the leg.
2. With the aid of the hexagon socket spanner size 6mm '3' screw the clamp '4'.
3. With the aid of an open-end spanner size 17mm-'5', tight the lock-nut '6'.

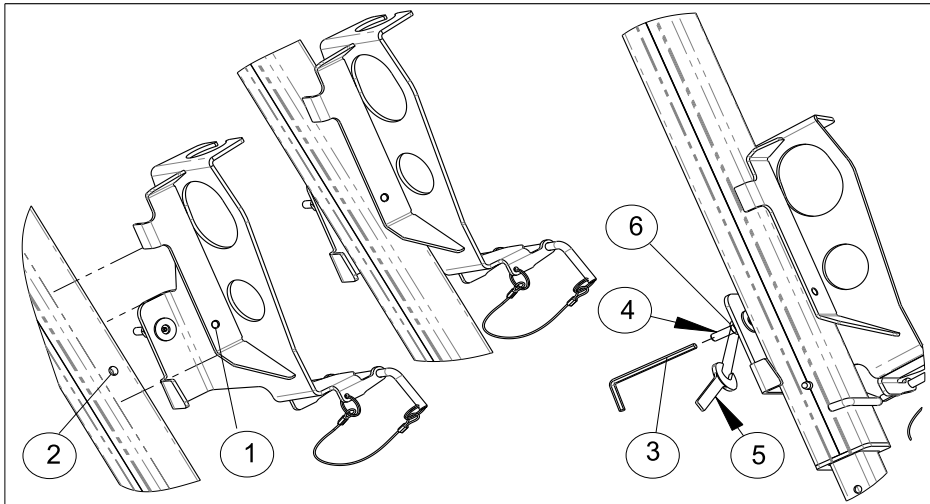

OPERATION

1. Before each use a visual inspection should be carried out by the user to ensure that the equipment is in serviceable condition and operates correctly. During pre-use check, any appearance and proper functioning should be checked.
2. The equipment should be withdrawn from use immediately in case of any doubt arise about its condition for safe use or it have been used to arrest a fall. Reusage only after detailed technical inspection and written confirmation by manufacturer's authorised service (e.g. in the PPE Identity Card).
3. The equipment should be protected during transportation and storage against: deformation or breaking, open fire or aggressive chemicals.
4. The usage of the AT172 bracket with any fault (such as: corrosion, cracks or deformation) is prohibited.
5. Anchoring to the AT172 bracket more than one person or suspend any loads is prohibited.

Mounting Bracket AT 172

INSPECTIONS, MAINTENANCE AND REPAIRING

1. The AT172 bracket should be periodically inspected every 12 month after first use. The periodic inspection must be conducted by a competent and qualified person. The result of inspection must be recorded in the PPE Identity Card.
2. During periodical inspections should be checked: legibility of the product marking, appearance of any defects (e.g.: cracks, deformation or corrosion) as well as functioning of the locking bar and screw clamp.
3. The equipment may be cleaned with the aid of water detergents or petrol type cleaning solutions. Do not use any acid or alkaline solutions. The bracket's screw clamp may be greased if necessary.
4. Replacement of the locking bar and/or its holding cord is only allowed within repairing of the equipment.
5. In case of any doubt please contact with producer or its authorised representatives.

ESSENTIAL RULES OF A SAFETY EQUIPMENT APPLICATION

1. This manual must be read before installation of the AT172 mounting bracket and before using as well. The instruction must be followed.
2. This instruction manual must be kept available to all users. Additional copies can be delivered on request by producer or distributor.
3. The equipment shall only be used by a person trained and competent in its safe use.
4. A rescue plan shall be in place to deal with any emergencies that could arise during the work.
5. Any modification of the anchor point is prohibited and any repair shall only be carried out in accordance with manufacturer's written procedures.
6. Personal protective equipment in association of the AT172 must not be used by people whose health condition may influence their safety during normal use or emergency procedures.
7. Rules of usage the fall protection system accompanied to the AT172 must conform to fall arresters, EN1496 - rescue lifting devices).
8. The AT172 bracket shall be used exclusively for attaching the CRW300 device to a EN363 standard and standards of applied equipment (especially to EN360 - retractable EN795-B safety tripod and for purposes covered by EN360 or EN1496 standards. Any other applications are forbidden without prior written agreement with producer or authorised representatives.
9. Any dangerous that may arise by the use of combinations of items of equipment in which the safe function of any one item is affected by or interferes with the safe function of another should be assessed.
10. Any hazards, that may affect the performance of the equipment and corresponding safety precautions, have to be observed during equipment utilization, especially: - trailing or looping of device lanyard over sharp edges,- pendulum falls, - extreme temperature, - chemical reagents, - electrical conductivity; - dust laden and greasy environment.
11. The person who assembles the AT172 bracket takes full responsibility for the assembly. Neither the manufacturer nor the distributor are responsible for an assembly that is careless and incompliant with the guidelines. On request, the manufacturer and/or distributor deliver all the necessary technical information concerning the product, the technology of its assembly, the way of checking it and the product certificate of compliance.
12. If the product is re-sold outside the original country of destination this instruction should be provided in the language of the country in which the product is to be used.